



Your application, our system

# The NEW Signet 9950 Dual Channel Transmitter

# Setup Ease of a Transmitter with the Versatility of a Controller



## 9950 Dual Channel Transmitter

The 9950 SmartPro Transmitter takes a simple approach to modularity. Choose from DC powered only or AC/DC powered system. The 9950 is ready to run out of the box with its standard two 4 to 20 mA passive outputs. Add optional relay modules and binary inputs, and transform your SmartPro in to a two channel controller. With onboard clock/calendar, derived functions, and advanced relay operation, you have seemingly countless configurations to meet your process control needs.

### + Applications

- Water Treatment
- Wastewater Treatment
- Reverse Osmosis
- Deionization
- Media Filtration
- Chemical Manufacturing/Addition
- Metal Finishing
- Fume Scrubber
- Odor Control
- Cooling Tower
- Chemical Dosing/ Injection
- Aquatic Life Support
- Pools & Fountains
- Rinse Tanks
- Chemical Neutralization

### + Features and benefits

- Out of the box "Easy Setup" prompts user for general settings that allows for faster system commissioning.
- True independent two channel Multi-Parameter input selection allows mix and match of frequency, (S<sup>3</sup>L), or 4 to 20 mA to (S<sup>3</sup>L), providing a multitude of measurement capabilities.
- Custom independent channel labeling for easy process identification.
- Sensor recognition aids in parameter identification for simple channel setup.
- Adjustable backlighting allows for clear viewing, even in the darkest areas.
- Optional relay module with 4 dry contact relays (SPDT) for a wide variety of functions including Low, High, Timer, and Proportional Pulse.
- Optional relay module with 2 dry contact (SPDT Relays) and 4 binary input (switches) means added parameter feedback in the form of flow, level, pressure etc., giving up to a total of six process inputs.
- Advanced Boolean logic allows for up to three process inputs per relay meaning more control options.
- The integrated USB port allows field upgrades so there is no need to pull the unit from service.
- The Derived Function feature allows for two like channel measurement comparisons such as Sum, Delta (difference), and Ratio to be displayed and outputted via relay or loop (4 to 20 mA).

### Approvals



UL Pending

## Technical features

The 9950 includes advanced features such as derived functions, advanced multiple relay modes, and timer-based relay functions. Derived functions allows for the control of a relay or current loop with the sum, delta (difference), or ratio of two measurements, for example, delta pressure and delta temperature. The 9950 has a state-of-the-art microprocessor, dot matrix display, ¼ DIN size, NEMA 4X front face, dual power 12 to 24 VDC, or 100 to 240 VAC, calendar and clock function.

### Specifications

<b>Input Channels</b>	Two frequency or S <sup>3</sup> L inputs	
<b>Window</b>	Shatter-resistant glass	
<b>Keypad</b>	4 buttons, injection-molded silicone rubber seal	
<b>Display</b>	Dot matrix, LCD	
<b>Indicators</b>	Two horizontal digital bar graphs, four LED relay status indicators	
<b>Size</b>	¼ DIN	
<b>DC Power</b>	-10 °C to 70 °C	14 °F to 158 °F
<b>AC Power</b>	-10 °C to 60 °C	14 °F to 140 °F
<b>Storage Temp</b>	-15 °C to 70 °C	5 °F to 158 °F
<b>Voltage</b>	+4.9 to 5.5 VDC @ 25 °C, regulated	
<b>Enclosure Rating</b>	NEMA 4X/IP65 (front face only)	



### USB

- Upgrade to the latest software features and hardware options
- Requires a standard USB flash drive
- Updates available on GF website



### Red Backlight

- This feature is available in the Options menu and is designed to visually alert personnel in the event of a sensor fault.



### Relay Options

- 4 channel mechanical relay module
- 2 mechanical and 2 solid state relay module
- 2 mechanical relays and 4 binary inputs



### Terminal Identification

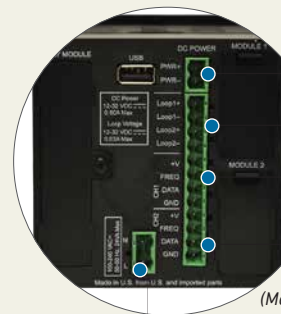

- DC Power Terminals
- Current Loop Outputs
- Channel 1 Input (Frequency/S<sup>3</sup>L)
- Channel 2 Input (Frequency/S<sup>3</sup>L)

• AC Power Terminals

(Module 1 and Module 2 for future use)

# + Compatibility

Independent Dual Channel Multi-Parameter, Flow, pH, ORP, Conductivity, Resistivity, Pressure, Temperature, Level, Volume, Salinity, Dissolved Oxygen, Other (4 to 20 mA)



## Advanced Boolean Relay Logic

Can include any combination of up to three of the following inputs: Channel 1 or 2 Primary or Secondary values, or any of the 4 (optional) binary switch inputs.

- **(A | B | C)** means "Activate this relay when any condition (A, B, or C) is true." E.g., pump protection: Turn off pump if there's a Low Flow, or High Flow, or High Temperature condition.
- **(A & B & C)** means "Activate this relay when only all conditions (A, B, and C) are true." E.g., acid neutralization (batch treat): Low pH and Hi Level, and incoming Flow, triggers actuated 3-way diverter valve to separate holding tank.
- **(A | (B & C))** means "Activate this relay if A is true OR if B AND C are both true." E.g., Level Control: Hi Continuous level transmitter for controlling with point level switches for alarms. Hi Binary and Hi/Hi Binary. If level transmitter is outputting Hi level OR if both point level switches are HI this activates alarm providing redundancy and safety.
- **(A & (B | C))** means "Activate this relay only if A is true AND either B or C are also true." E.g., Rinse Tank Control: Machine is on, and Lo Level, or Hi Conductivity, activates water fill valve.

## Derived Functions

When two of the same type of measurement are present, the 9950 can calculate several derived functions from like pairs of measurements.

Up to three derived Functions can be defined and used as the source for display and output functions.

- Flow, Temperature, Pressure, Conductivity and Level channels must have matching units. (Flow channels must also have same time base).
- Conductivity channels will automatically scale to  $\mu\text{S}/\text{cm}$  before the function calculation is made.
- Three types of derived measurements can be applied to any set of sensors, regardless of type.
  - Ratio: Measurement 1  $\div$  Measurement 2 or Measurement 2  $\div$  Measurement 1
  - Delta (Difference): Measurement 1 - Measurement 2 or Measurement 2 - Measurement 1
  - Sum: Measurement 1 + Measurement 2

### % Passage and % Reject

- % Passage and % Reject are derived functions based on conductivity measurements only, specifically for use in reverse osmosis systems.
- % Passage is the amount of contaminants remaining in the product water compared to the level of contaminants in the feed water. For example, if the feed water measures  $375 \mu\text{S}$  and the product water measures  $18.75 \mu\text{S}$ , the % Passage is  $(18.75/375) \times 100 = 5\%$ .
- % Reject is the amount of contaminants rejected to the concentrate water compared to the amount of contaminants in the feed water. For example, if the feed water measures  $375 \mu\text{S}$  and the product water measures  $18.75 \mu\text{S}$  the % Reject is  $[1 - (18.75/375)] \times 100 = 95\%$
- Decreasing Reject values and increasing Passage values usually indicate a problem with the RO membrane.

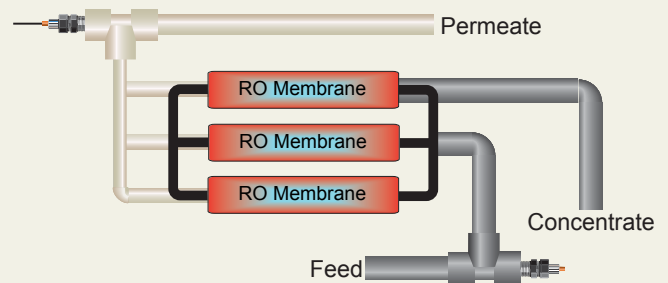

$$\% \text{ Passage: } (\text{Permeate} \div \text{Feed}) \times 100$$

$$\% \text{ Reject: } [1 - (\text{Permeate} \div \text{Feed})] \times 100$$

### % Recovery

- % Recovery is a derived function based on flow rate, in a reverse osmosis system.
- To measure % Recovery, the 9950 must have two flow sensors connected. They may be located in the Feed line, the Concentrate line or the Permeate line.
- The 9950 provides 3 different methods for calculating Recovery to accommodate any configuration.
- Both flow sensors must use the same time base and units of measure.

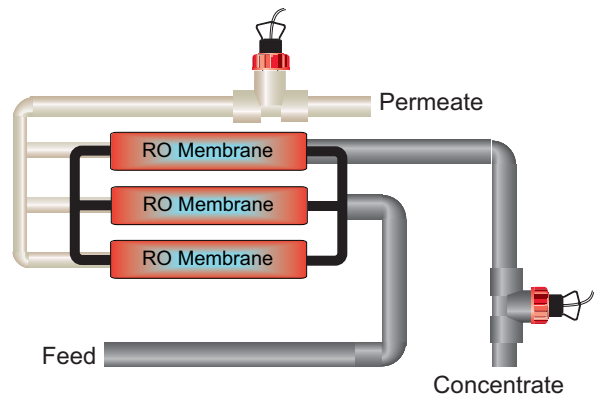

$$\% \text{ Recovery B: } \text{Permeate} \div (\text{Permeate} + \text{Concentrate}) \times 100$$

In the Setup menu, select the option that states  
**% Recovery B, PERMEATE: CONC**

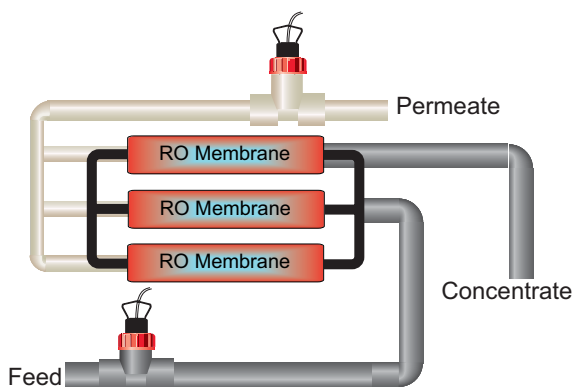

$$\% \text{ Recovery A: } (\text{Permeate} \div \text{Feed}) \times 100$$

In the Setup menu, select the option that states  
**% Recovery A, FEED: PERMEATE**

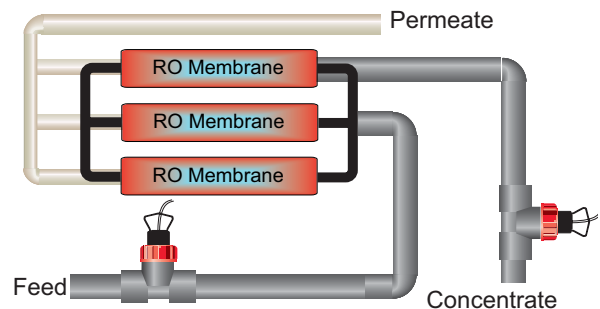

$$\% \text{ Recovery C: } [(\text{Feed} - \text{Concentrate}) \div \text{Feed}] \times 100$$

In the Setup menu, select the option that states  
**% Recovery C, FEED: CONC**

## Applications

# Reverse Osmosis

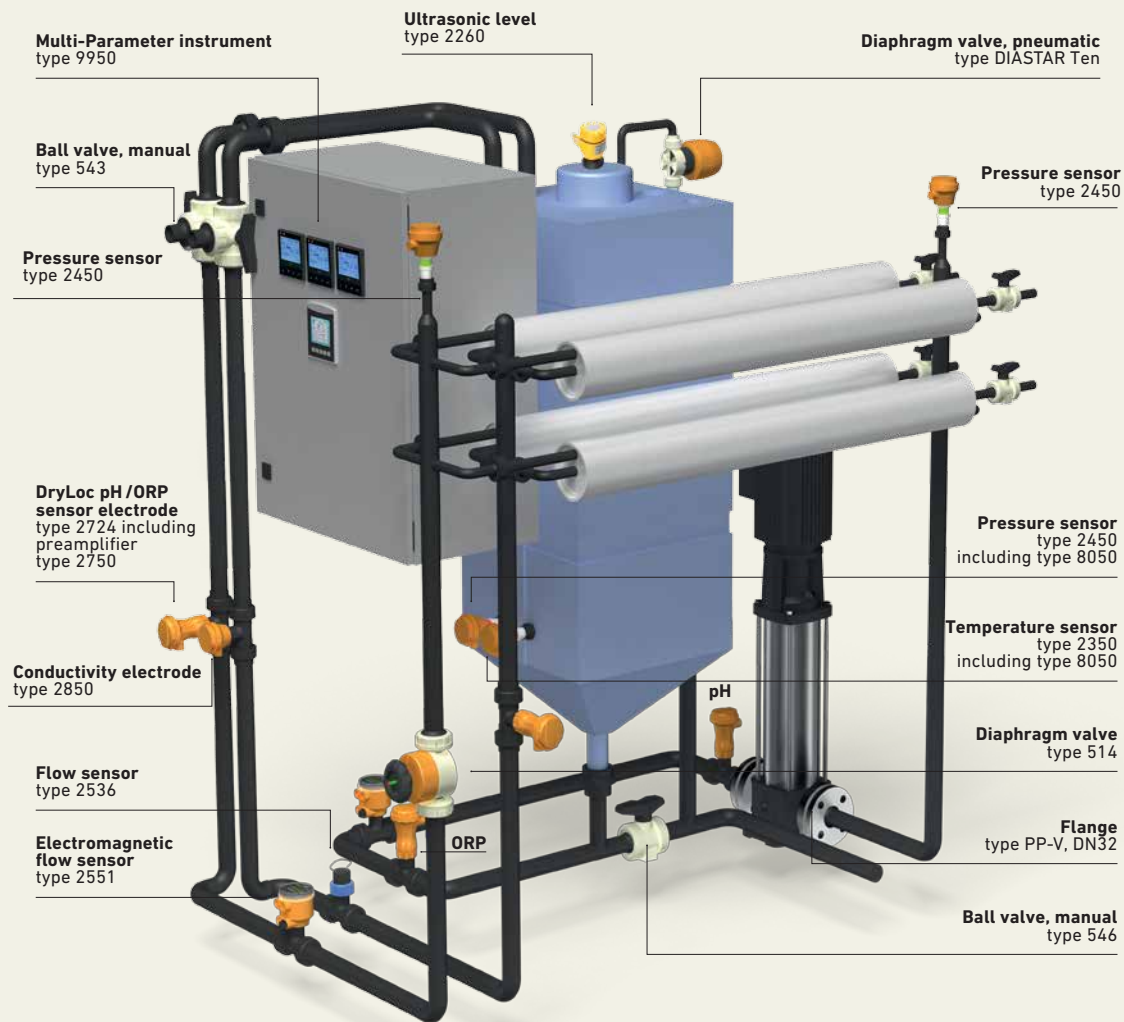

### Flow

1. Influent: Monitors the total amount of water being processed through the membrane to track maintenance schedule for backwash and cleaning.
2. Permeate: Monitors the amount of permeate water from the first stage in a double RO system or the amount of water for the final process.
3. Concentrate/wastewater: Tracks the amount of concentrate or brackish water being sent to drain.

Use the Signet 9950 to monitor two flows. Derived functions provide percent recovery (A, B, or C) based on application needs.

### Temperature

**Temperature:** Influent water temperature has a direct effect on the rejection rate of the membrane. Lower temperature reduces the ability of the membrane to reject minerals. Increased pressure is usually required to maintain product water levels.

### Pressure

**Pressure:** Pressure across the membrane is monitored (delta P). Too much pressure across the membrane can damage the elements inside. Use of two 2450's before and after the membrane fed into a 9950 setup for derived function (Delta P) can be used to alarm and protect the membranes from over pressure damage.

### pH/ORP

**pH:** Monitors pH for adjustment of incoming water membrane technology allows a wider window for process water at low pH levels. Many end users adjust pH on the front end of the RO process to reduce the amount of pH adjustment after the process is complete.

**ORP:** Monitors to ensure dechlorination is effective. Manufacturers of membranes require low levels of chlorine. In this case, a 9950 can be used to monitor and alarm anytime the pH or ORP values exceed the preprogrammed limits.

### Conductivity/TDS

(The membrane industry usually measures water quality in TDS (total dissolved solids)). Measuring the feed water TDS level and comparing it to the permeate TDS level allows the operator to monitor the amount of mineral rejection in the membrane. Rejection rate is an indicator of the membrane's efficiency. Foulants on the RO membrane surface can cause flux loss (permeate flow), an increase in differential pressure, higher product water conductivity, a need for increased feed pressure to maintain output or a combination of these effects.

Using the Signet 9950 to monitor Feed water and Permeate water conductivity can determine the efficiency of the RO membrane. Use of the derived function (Percent Reject) can be used to alarm/ signal the need for service based on diminished efficiency / Percent Reject.

## Applications

# Batch Neutralization & Effluent Monitoring

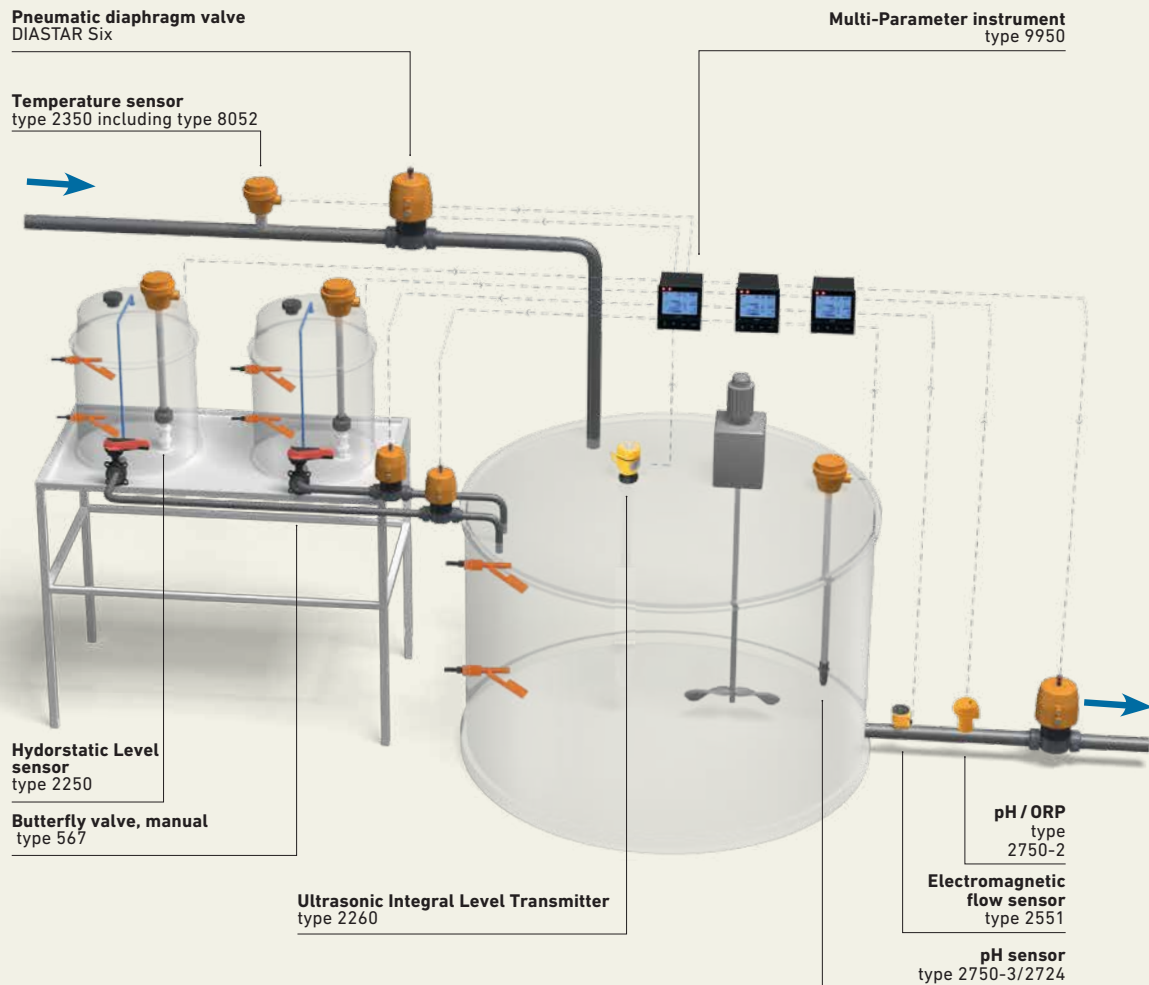

### Measurements in Reverse Osmosis

**Flow:** In many water treatment processes, the water needs to be adapted to a pH value that complies with treatment specifications. For example, wastewater must be neutralized before it is fed into public treatment plants. Alkaline or acidic wastewater is regulated by adjusting the pH value. For alkaline neutralization, several chemicals like caustic soda are generally used direct or in combination with a neutralization of a caustic solution. Sulphuric acid, hydrochloric acid or carbonic acids are often used as acids in a batch process.

### Batch Tank

**Level (Continuous & point):** Use of a 2260 / 2270 ultrasonic level sensor fed in to a 9950 to monitor batch treatment tank for fill and empty conditions. Add a 3-9950-3 two mechanical relay, four binary input module and add redundant level switch protection 2282's for high and low level binary inputs. All three level sensing devices can be tied into one relay through the use of the 9950's Advanced Boolean Logic function.

### pH

**pH:** Utilizing a 2750-3 submersible pH sensor and 3-2724 pH electrode, you can tie in to the above level system. Use the two 4 to 20 mA loop outputs to proportionally drive chemical metering pumps to draw chemicals (acid or caustic) from the chemical drums.

### Chemical Tank and Effluent Monitoring

**Level:** Use continuous level 2250 sensors into one 9950 to monitor refill requirements. Add a 3-9950-3 two mechanical relay, four binary input module and add redundant safety level switch protection 2282's for high and low level binary inputs. One controller with six points of level input.

**Flow & pH:** Use a 2551 magnetic flow meter for reporting purposes, and a 3-2750-X in-line sensor for effluent recording. Add a 3-9950-1 four mechanical relay module. Program one relay for window out alarm set at 6 pH -9 pH. Relay can be tied to 3-Way Georg Fischer Electrically Actuated valve for diversion of improperly treated liquid, preventing an out of compliance condition with the local authority.

# Worldwide at home

Our sales companies and representatives ensure local customer support in over 100 countries.

[www.gfps.com](http://www.gfps.com)

## Argentina / Southern South America

Georg Fischer Central Plastics  
Sudamérica S.R.L.  
Buenos Aires, Argentina  
Phone +54 11 4512 02 90  
[gfcentral.ps.ar@georgfischer.com](mailto:gfcentral.ps.ar@georgfischer.com)  
[www.gfps.com/ar](http://www.gfps.com/ar)

## Australia

George Fischer Pty Ltd  
Riverwood NSW 2210 Australia  
Phone +61 (0) 2 9502 8000  
[australia.ps@georgfischer.com](mailto:australia.ps@georgfischer.com)  
[www.gfps.com/au](http://www.gfps.com/au)

## Austria

Georg Fischer  
Rohrleitungssysteme GmbH  
3130 Herzogenburg  
Phone +43 (0) 2782 856 43-0  
[austria.ps@georgfischer.com](mailto:austria.ps@georgfischer.com)  
[www.gfps.com/at](http://www.gfps.com/at)

## Belgium / Luxembourg

Georg Fischer NV/SA  
1070 Bruxelles/Brüssel  
Phone +32 (0) 2 556 40 20  
[be.ps@georgfischer.com](mailto:be.ps@georgfischer.com)  
[www.gfps.com/be](http://www.gfps.com/be)

## Brazil

Georg Fischer Sist. de Tub. Ltda.  
04795-100 São Paulo  
Phone +55 (0) 11 5525 1311  
[br.ps@georgfischer.com](mailto:br.ps@georgfischer.com)  
[www.gfps.com/br](http://www.gfps.com/br)

## Canada

Georg Fischer Piping Systems Ltd  
Mississauga, ON L5T 2B2  
Phone +1 (905) 670 8005  
Fax +1 (905) 670 8513  
[ca.ps@georgfischer.com](mailto:ca.ps@georgfischer.com)  
[www.gfps.com/ca](http://www.gfps.com/ca)

## China

Georg Fischer Piping Systems Ltd  
Shanghai 201319  
Phone +86 21 3899 3899  
[china.ps@georgfischer.com](mailto:china.ps@georgfischer.com)  
[www.gfps.com/cn](http://www.gfps.com/cn)

## Denmark / Iceland

Georg Fischer A/S  
2630 Taastrup  
Phone +45 (0) 70 22 19 75  
[info.dk.ps@georgfischer.com](mailto:info.dk.ps@georgfischer.com)  
[www.gfps.com/dk](http://www.gfps.com/dk)

## Finland

Georg Fischer AB  
01510 VANTAA  
Phone +358 (0) 9 586 58 25  
Fax +358 (0) 9 586 58 29  
[info.fi.ps@georgfischer.com](mailto:info.fi.ps@georgfischer.com)  
[www.gfps.com/fi](http://www.gfps.com/fi)

## France

Georg Fischer SAS  
95932 Roissy Charles de Gaulle Cedex  
Phone +33 (0) 1 41 84 68 84  
[fr.ps@georgfischer.com](mailto:fr.ps@georgfischer.com)  
[www.gfps.com/fr](http://www.gfps.com/fr)

## Germany

Georg Fischer GmbH  
73095 Albershausen  
Phone +49 (0) 7161 302-0  
[info.de.ps@georgfischer.com](mailto:info.de.ps@georgfischer.com)  
[www.gfps.com/de](http://www.gfps.com/de)

## India

Georg Fischer Piping Systems Ltd  
400 076 Mumbai  
Phone +91 224007 2001  
[branchoffice@georgfischer.com](mailto:branchoffice@georgfischer.com)  
[www.gfps.com/in](http://www.gfps.com/in)

## Indonesia

George Fischer Pte Ltd –  
Representative Office  
Phone +62 21 2900 8564  
Fax +62 21 2900 8566  
[sgp.ps@georgfischer.com](mailto:sgp.ps@georgfischer.com)  
[www.gfps.com/sg](http://www.gfps.com/sg)

## Italy

Georg Fischer S.p.A.  
20063 Cernusco S/N (MI)  
Phone +39 02 921 861  
[it.ps@georgfischer.com](mailto:it.ps@georgfischer.com)  
[www.gfps.com/it](http://www.gfps.com/it)

## Japan

Georg Fischer Ltd  
556-0011 Osaka,  
Phone +81 (0) 6 6635 2691  
[jp.ps@georgfischer.com](mailto:jp.ps@georgfischer.com)  
[www.gfps.com/jp](http://www.gfps.com/jp)

## Korea

GF Piping Systems  
Georg Fischer Korea Co., Ltd.  
Unit 2501, U-Tower  
120 HeungdeokJungang-ro (Yeongdeok-dong)  
Giheung-gu, Yongin-si, Gyeonggi-do, Korea  
Phone: +82 31 8017 1450  
Fax: +82 31 217 1454  
[kor.ps@georgfischer.com](mailto:kor.ps@georgfischer.com)  
[www.gfps.com/kr](http://www.gfps.com/kr)

## Malaysia

George Fischer (M) Sdn. Bhd.  
40460 Shah Alam, Selangor Darul Ehsan  
Phone +60 (0) 3 5122 5585  
Fax +603 5122 5575  
[my.ps@georgfischer.com](mailto:my.ps@georgfischer.com)  
[www.gfps.com/my](http://www.gfps.com/my)

## Mexico / Northern Latin America

Georg Fischer S.A. de C.V.  
Apodaca, Nuevo Leon  
CP66636 Mexico  
Phone +52 (81) 1340 8586  
Fax +52 (81) 1522 8906  
[mx.ps@georgfischer.com](mailto:mx.ps@georgfischer.com)  
[www.gfps.com/mx](http://www.gfps.com/mx)

## Middle East

Georg Fischer  
Piping Systems (Switzerland) Ltd  
Dubai, United Arab Emirates  
Phone +971 4 289 49 60  
[gcc.ps@georgfischer.com](mailto:gcc.ps@georgfischer.com)  
[www.gfps.com/int](http://www.gfps.com/int)

## Netherlands

Georg Fischer N.V.  
8161 PA Epe  
Phone +31 (0) 578 678 222  
[nl.ps@georgfischer.com](mailto:nl.ps@georgfischer.com)  
[www.gfps.com/nl](http://www.gfps.com/nl)

## Norway

Georg Fischer AS  
1351 Rud  
Phone +47 67 18 29 00  
[no.ps@georgfischer.com](mailto:no.ps@georgfischer.com)  
[www.gfps.com/no](http://www.gfps.com/no)

## Philippines

George Fischer Pte Ltd  
Representative Office  
Phone +632 571 2365  
Fax +632 571 2368  
[sgp.ps@georgfischer.com](mailto:sgp.ps@georgfischer.com)  
[www.gfps.com/sg](http://www.gfps.com/sg)

## Poland

Georg Fischer Sp. z o.o.  
05-090 Sekocin Nowy  
Phone +48 (0) 22 31 31 0 50  
[poland.ps@georgfischer.com](mailto:poland.ps@georgfischer.com)  
[www.gfps.com/pl](http://www.gfps.com/pl)

## Romania

Georg Fischer  
Piping Systems (Switzerland) Ltd  
020257 Bucharest - Sector 2  
Phone +40 (0) 21 230 53 80  
[ro.ps@georgfischer.com](mailto:ro.ps@georgfischer.com)  
[www.gfps.com/int](http://www.gfps.com/int)

## Russia

Georg Fischer  
Piping Systems (Switzerland) Ltd  
Moscow 125047  
Phone +7 495 258 60 80  
[ru.ps@georgfischer.com](mailto:ru.ps@georgfischer.com)  
[www.gfps.com/ru](http://www.gfps.com/ru)

## Singapore

George Fischer Pte Ltd  
11 Tampines Street 92, #04-01/07  
528 872 Singapore  
Phone +65 6747 0611  
Fax +65 6747 0577  
[sgp.ps@georgfischer.com](mailto:sgp.ps@georgfischer.com)  
[www.gfps.com/sg](http://www.gfps.com/sg)

## Spain / Portugal

Georg Fischer S.A.  
28046 Madrid  
Phone +34 (0) 91 781 98 90  
[es.ps@georgfischer.com](mailto:es.ps@georgfischer.com)  
[www.gfps.com/es](http://www.gfps.com/es)

## Sweden

Georg Fischer AB  
117 43 Stockholm  
Phone +46 (0) 8 506 775 00  
[info.se.ps@georgfischer.com](mailto:info.se.ps@georgfischer.com)  
[www.gfps.com/se](http://www.gfps.com/se)

## Switzerland

Georg Fischer  
Rohrleitungssysteme (Schweiz) AG  
8201 Schaffhausen  
Phone +41 (0) 52 631 30 26  
[ch.ps@georgfischer.com](mailto:ch.ps@georgfischer.com)  
[www.gfps.com/ch](http://www.gfps.com/ch)

## Taiwan

Georg Fischer Co., Ltd  
San Chung Dist., New Taipei City  
Phone +886 2 8512 2822  
Fax +886 2 8512 2823  
[www.gfps.com/tw](http://www.gfps.com/tw)

## United Kingdom / Ireland

George Fischer Sales Limited  
Coventry, CV2 2ST  
Phone +44 (0) 2476 535 535  
[uk.ps@georgfischer.com](mailto:uk.ps@georgfischer.com)  
[www.gfps.com/uk](http://www.gfps.com/uk)

## USA / Caribbean

Georg Fischer LLC  
9271 Jeronimo Road  
92618 Irvine, CA  
Phone +1 714 731 88 00  
Fax +1 714 731 62 01  
[us.ps@georgfischer.com](mailto:us.ps@georgfischer.com)  
[www.gfps.com/us](http://www.gfps.com/us)

## International

Georg Fischer  
Piping Systems (Switzerland) Ltd  
8201 Schaffhausen/Switzerland  
Phone +41 (0) 52 631 30 03  
Fax +41 (0) 52 631 28 93  
[info.export@georgfischer.com](mailto:info.export@georgfischer.com)  
[www.gfps.com/int](http://www.gfps.com/int)

## GF Piping Systems

Tel. (714) 731-8800, Toll Free (800) 854-4090

Fax (714) 731-6201

[us.ps@georgfischer.com](mailto:us.ps@georgfischer.com), [www.gfpiping.com](http://www.gfpiping.com)

The technical data is not binding. They neither constitute expressly warranted characteristics nor guaranteed properties nor a guaranteed durability. They are subject to modification. Our General Terms of Sale apply.

