

F-460

1/2" and 3/4" Pipe Sizes

F/NPT and Socket Fusion connections

Rib Guided Float

No Metal in the fluid path



Features:

- Polysulfone meter body resists high temperatures and pressures.
- PTFE float and optional PVC, Polypropylene or PVDF adapters for corrosive applications.
- Rib guided float.
- No metal in the fluid path.
- Direct reading permanent scale.

Materials of Construction:

- Meter Body: Polysulfone
- Adapters: PVC (optional Polypropylene & PVDF)
- O-ring seals: Viton[®] (optional EP)
- Union Nuts: Anodized Aluminum (optional PVC)
- Float: PTFE
- Float Stop: Polysulfone

Specifications:

Max. working pressure: 150 PSI (10.3 bar) @ 70° F (21° C)

Max. fluid temperature:

PVC adapters: 130° F (54° C) @ 0 PSI

Polypropylene adapters: 150° F (65° C) @ 0 PSI

PVDF adapters: 210° F (98° C) @ 0 PSI

Full scale accuracy: +/- 2.5%

Calibration fluid: water, specific gravity 1.0

Scale length: 4" (100mm)

Environment: Not for direct sunlight exposure.

Maximum pressure drop: 2 PSI

Approximate shipping wt: 1 lb. (.45 kg)

Dimensions:

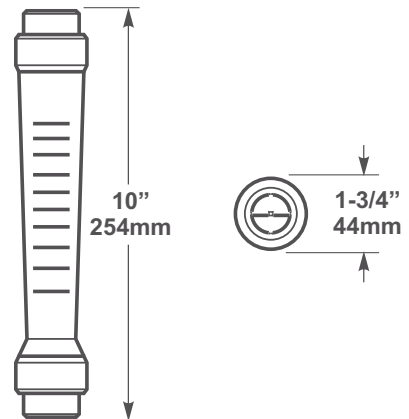

Maximum Temperature vs. Pressure

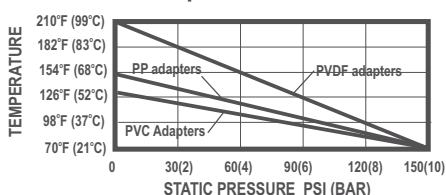

Installation Requirements:

1. Misalignment will damage the meter!

Flowmeter must be installed in an exact vertical plane to ensure accuracy. Be certain of proper plumbing alignments. Misalignment may cause the o-ring seals to leak. The meterbody material can be damaged by UV rays. **Do not install in direct sunlight.**

2. Pipe dope and glue will damage the meter!

Use only PTFE tape on the threaded adapters. The meter body and plastic fittings cannot tolerate PVC Glue and/or pipe dope. Even fumes can cause severe damage. If you are installing your flowmeter to a glued pipe configuration, install the flowmeter *after* all glued fittings are dried and lines are purged of all fumes. **Never** hold the meter body with pliers or like tools. Union nuts should be hand tightened only. **DO NOT OVER-TIGHTEN!**

3. Vibration and heavy loads will damage the meter!

Wall, floor and ceiling mounts and supports must be carefully aligned with the meter body and sturdy enough to support the plumbing and prevent vibration. Never allow the flowmeter to support the weight of related piping.

4. Solenoid valves will damage the meter!

Avoid a system that will impose a sudden burst of flow to the meter. Such a burst will cause the float to impact the float stop with destructive force. Solenoid valves, or other quick opening valves cannot be used unless meter is protected against sudden bursts of flow.

5. High pressures and temperatures will damage the meter!

The maximum acceptable temperature and pressure is interdependent. The maximum acceptable working pressure is dependant on the actual fluid temperature. The maximum acceptable fluid temperature is dependant on the actual working pressure. (see Temperature Vs. Pressure chart).

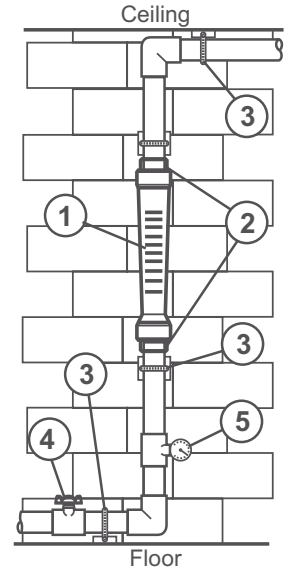

Flow Range and Model Options:

Models with F/NPT connections

- Models for Liquid with PVC adapters

MODEL NUMBER	Dual Scale Range GPM	Range LPM	Adapter F/NPT	Float Material	Adapter Material
F-46010LX-08P	0.1 to 1.2	0.4 to 4.4	1/2"	PTFE	PVC
F-46010LX-12P	0.1 to 1.2	0.4 to 4.4	3/4"	PTFE	PVC
F-46020LX-08P	0.2 to 2.0	0.8 to 8.0	1/2"	PTFE	PVC
F-46020LX-12P	0.2 to 2.0	0.8 to 8.0	3/4"	PTFE	PVC
F-46030LX-08P	0.3 to 3.0	1.0 to 11	1/2"	PTFE	PVC
F-46030LX-12P	0.3 to 3.0	1.0 to 11	3/4"	PTFE	PVC
F-46050LX-08P	0.5 to 5.0	2.0 to 20	1/2"	PTFE	PVC
F-46050LX-12P	0.5 to 5.0	2.0 to 20	3/4"	PTFE	PVC

- Models for Liquid with PVDF adapters

MODEL NUMBER	Dual Scale Range GPM	Range LPM	Adapter F/NPT	Float Material	Adapter Material
F-46010LX-08K	0.1 to 1.2	0.4 to 4.4	1/2"	PTFE	PVDF
F-46010LX-12K	0.1 to 1.2	0.4 to 4.4	3/4"	PTFE	PVDF
F-46020LX-08K	0.2 to 2.0	0.8 to 8.0	1/2"	PTFE	PVDF
F-46020LX-12K	0.2 to 2.0	0.8 to 8.0	3/4"	PTFE	PVDF
F-46030LX-08K	0.3 to 3.0	1.0 to 11	1/2"	PTFE	PVDF
F-46030LX-12K	0.3 to 3.0	1.0 to 11	3/4"	PTFE	PVDF
F-46050LX-08K	0.5 to 5.0	2.0 to 20	1/2"	PTFE	PVDF
F-46050LX-12K	0.5 to 5.0	2.0 to 20	3/4"	PTFE	PVDF

Models listed above are LX variation = units with Anodized Aluminum unions.
LP = units with PVC unions.

Models with Socket Fusion connections

- Models for Liquid with Polypropylene adapters

MODEL NUMBER	Dual Scale Range GPM	Range LPM	Adapter S.F.	Float Material	Adapter Material
F-46010LX-09G	0.1 to 1.2	0.4 to 4.4	1/2"	PTFE	Polypropylene
F-46010LX-13G	0.1 to 1.2	0.4 to 4.4	3/4"	PTFE	Polypropylene
F-46020LX-09G	0.2 to 2.0	0.8 to 8.0	1/2"	PTFE	Polypropylene
F-46020LX-13G	0.2 to 2.0	0.8 to 8.0	3/4"	PTFE	Polypropylene
F-46030LX-09G	0.3 to 3.0	1.0 to 11	1/2"	PTFE	Polypropylene
F-46030LX-13G	0.3 to 3.0	1.0 to 11	3/4"	PTFE	Polypropylene
F-46050LX-09G	0.5 to 5.0	2.0 to 20	1/2"	PTFE	Polypropylene
F-46050LX-13G	0.5 to 5.0	2.0 to 20	3/4"	PTFE	Polypropylene

- Models for Liquid with PVDF adapters

MODEL NUMBER	Dual Scale Range GPM	Range LPM	Adapter S.F.	Float Material	Adapter Material
F-46010LX-09K	0.1 to 1.2	0.4 to 4.4	1/2"	PTFE	PVDF
F-46010LX-13K	0.1 to 1.2	0.4 to 4.4	3/4"	PTFE	PVDF
F-46020LX-09K	0.2 to 2.0	0.8 to 8.0	1/2"	PTFE	PVDF
F-46020LX-13K	0.2 to 2.0	0.8 to 8.0	3/4"	PTFE	PVDF
F-46030LX-09K	0.3 to 3.0	1.0 to 11	1/2"	PTFE	PVDF
F-46030LX-13K	0.3 to 3.0	1.0 to 11	3/4"	PTFE	PVDF
F-46050LX-09K	0.5 to 5.0	2.0 to 20	1/2"	PTFE	PVDF
F-46050LX-13K	0.5 to 5.0	2.0 to 20	3/4"	PTFE	PVDF

Models listed above are LX variation = units with Anodized Aluminum unions.
LP = units with PVC unions.

Correction factor formulas for AIR models

PRESSURE CORRECTION

$$\sqrt{\frac{14.7 + \text{Working PSIG}}{14.7}}$$

TEMPERATURE CORRECTION

$$\sqrt{\frac{520}{460 + \text{Working Temp } ^\circ\text{F}}}$$

Notes:

1) Liquid models calibrated with water, Sp.Gr. 1.0. Custom Sp.Gr. calibrations available. Contact the factory.

2) Air models calibrated at standard Conditions (70°F @ 14.7 PSia). Temperature and pressure correction may be required. Contact the factory for custom calibrations.

3) Gallons shown are U.S. Gallons.